



Two-phase gas–liquid flow in horizontal corrugated channels

M. Gradeck*, M. Lebouché

LEMTA CNRS UMR 7563, 2 Avenue de la Forêt de Haye, BP 160, F-54504, Vandoeuvre Cedex, France

Received 10 February 1997; received in revised form 24 February 1999

Abstract

Experiments have been carried out for adiabatic concurrent gas–liquid flow of nitrogen and water through two corrugated test sections. This study examines flow patterns as the gas fluxes are increased. At low gas fluxes two main patterns have been observed: stratified flow for low liquid fluxes and bubble flow for greater ones. The mean wall shear stress of the two-phase flow has been measured with the electrochemical method (polarography); its analysis reveals the flow structure modification from monophasic to two-phase flow. © 2000 Elsevier Science Ltd. All rights reserved.

1. Introduction

Most of the gas–liquid studies involved large circular tubes because it is the most appropriate geometry which can withstand the high pressure. However, these past 30 years, the two-phase gas–liquid flow inside compact heat exchangers received much more attention from the scientific community. The technological progress allowed welding of the plates, so that the plate heat exchangers can withstand high pressure and high temperature (600°C).

A clear understanding of the effects of corrugated channels on gas–liquid flow is essential to improved design procedures. Hugonnot et al. (1989) have carried both numerical and experimental work on the monophasic newtonian flow in corrugated geometries. Bereiziat (1993) analyses the flow of complex fluids. Gradeck and Lebouché (1998) investigate adiabatic

* Corresponding author.

single phase flow inside such channels using the electrochemical technique. Considering the two-phase flow studies carried in complex geometries like corrugated plates, no articles have been found on this specific topic. These comments are sufficient to justify this first study.

The aim of this study is firstly to determine the gas–liquid flow patterns in two corrugated channels when the gas flux increases. The second part of this study is concerned by the analysis of the local flow structure from measurements of the wall shear stress by the electrochemical technique. Application of the electrochemical technique for hydrodynamic studies is known for up to 30 years. The principle of this technique has been widely described in the past by Reiss and Hanratty (1963) and Lebouché (1968). This non-intrusive technique is the only one that allows measurements at the wall. The method, also called polarography, has been extended for wall shear stress measurements in gas–liquid flow by Souhar et al. (1984).

2. Experimental facility

The schematic of the loop we used in these experiments is shown in Fig. 1. All its elements are built with inert materials because of the electrochemical technique. Nitrogen gas was used because the accuracy of the electrochemical technique is affected by the presence of dissolved oxygen in the aqueous solution. The liquid (electrochemical solution) is supplied from a tank and circulates thanks to a centrifugal pump. After the mixture has passed through the test section, the liquid is collected in the main tank while the gas is not recycled.

The two test sections are corrugated channels whose characteristic dimensions are given in

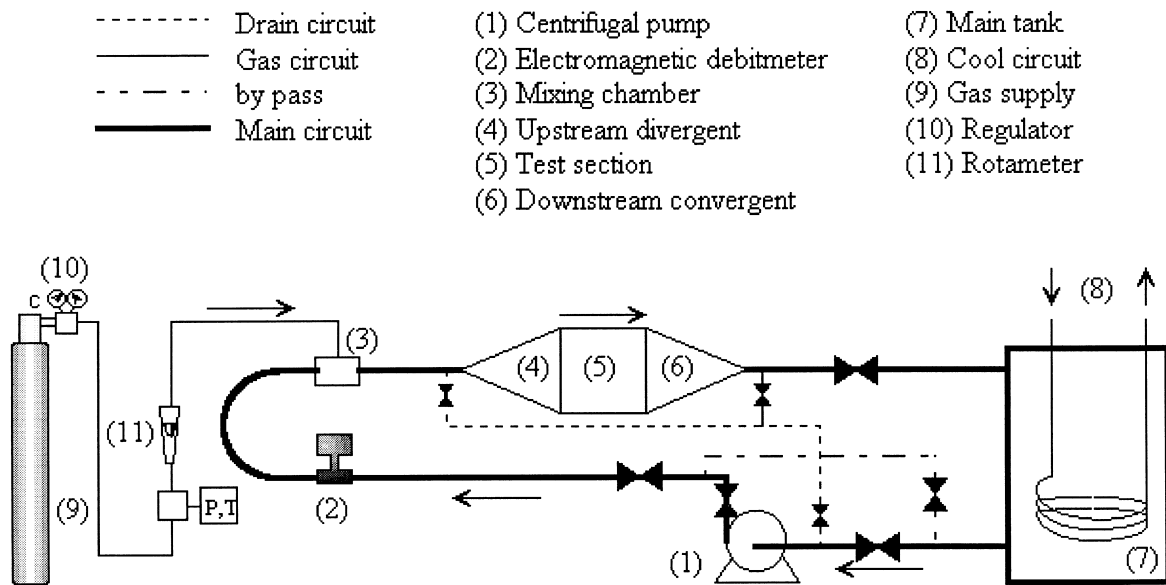

Fig. 1. Schematic of the flow loop.

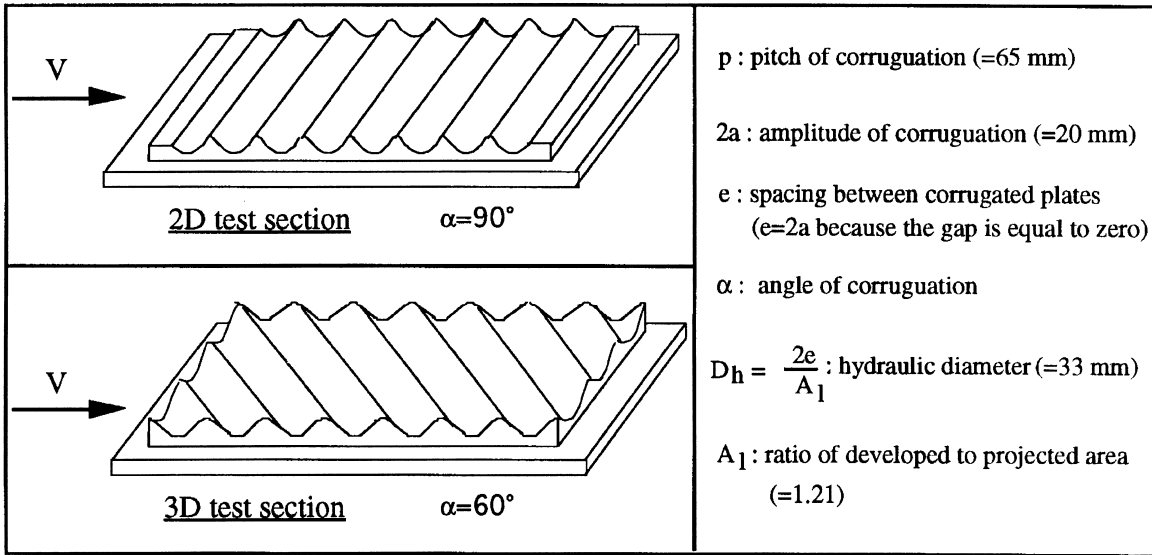

Fig. 2. Characteristic dimensions of the channels.

Fig. 2. These scale models (the scale is 5–1) represent an industrial heat exchanger. The main difference between the two models is the angle between the corrugations and the main flow direction. These channels are made of plexiglass to allow flow visualization. They contain electrochemical probes inserted flush to the wall of the duct, nine circular probes were inserted and were distributed on a pitch of a corrugation (Fig. 3).

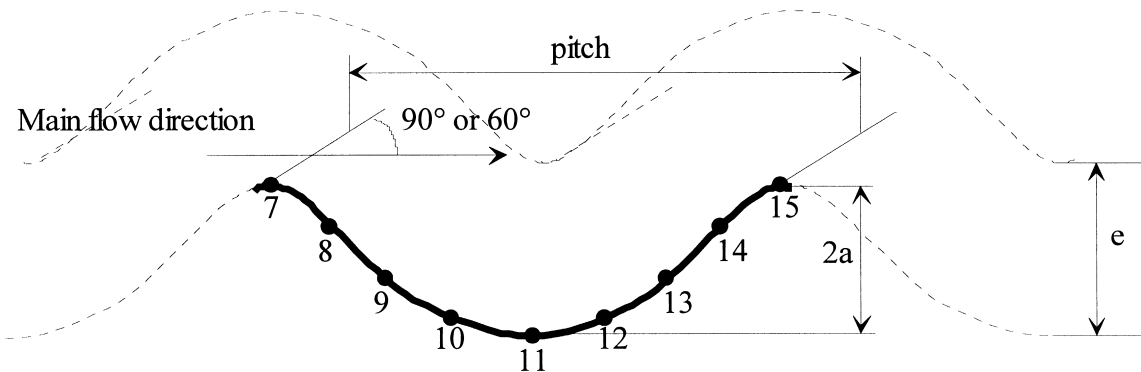

Fig. 3. Schematic location of the circular probes. In the case of a wall dryout, the current delivered by the electrode does fall down brutally to zero. So instantaneous signal delivered by the probes can indicate if the flow is stratified or not. In the negative case, the dryout ratio Δ (dryout time/total time) equals to zero.

3. Results and discussion

3.1. Visualization of the flow: flow patterns

Two patterns and their associated transition boundaries have been determined from direct visual observations and from a video movie. The superficial liquid velocity V_{LS} was fixed and the different flow patterns were observed while the superficial gas velocity V_{GS} was increased. The two-dimensional (2D) channel was observed through its lateral face and the three-dimensional (3D) channel was observed through its upper face.

The two main patterns observed are stratified and bubble flow. We have not observed an intermittent regime like slug or plug flow.

3.2. Case of the 2D channel

Stratified flow is observed for superficial liquid velocities lower than 0.3 m/s. For larger values bubble flow takes place.

$V_{LS} < 0.3$ m/s The stratified flow observed in this particular channel is not the classical one observed in a smooth channel. In the 2D test section, the gas phase is trapped in the upper part of the channel and forms a large inclined plug because the liquid phase exerts pressure on it. The gas phase is not a continuous one like in traditional stratified pattern, but it flows because small bubbles are pulling out from the big bubble (Fig. 4). The simple examination of the dryout ratio (probe 11 in the upper plate) shows that the wall is wetted from time-to-time. This is sufficient to say that this flow pattern is a real Stratified one (Fig. 5).

$V_{LS} > 0.3$ m/s The transition from stratified to bubble flow is brutal, no intermittent flow is observed. However, the bubble distribution shows the effect of a residual stratification for superficial liquid velocities lower than 0.4 m/s; then, the bubble distribution is more homogeneous. In all case, concentrations and recirculating zones are observed in the wake of the corrugations (Fig. 6).

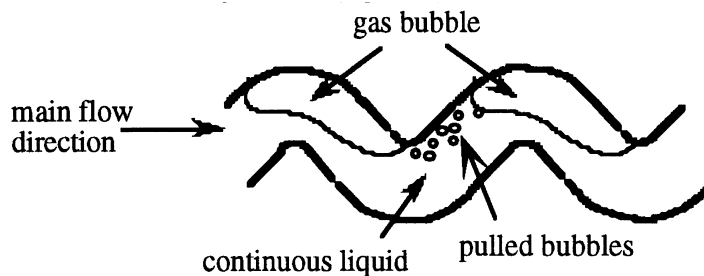

Fig. 4. Schematic of the stratified flow in the 2D channel.

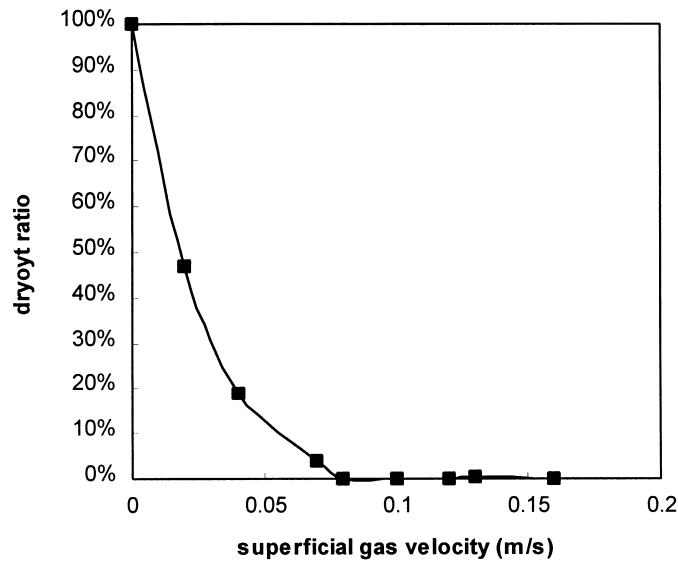

Fig. 5. Dryout ratio evolution (probe 11).

3.3. Case of the 3D channel

The same patterns are observed but the transition from stratified to bubble flow is observed for superficial liquid velocities values close to 0.25 m/s; the dispersion of bubbles is precocious. In the case of the Stratified pattern, the gas phase cannot be trapped in the upper part of the channel like in the 2D geometry; this time, it can flow not only along the furrows but also in

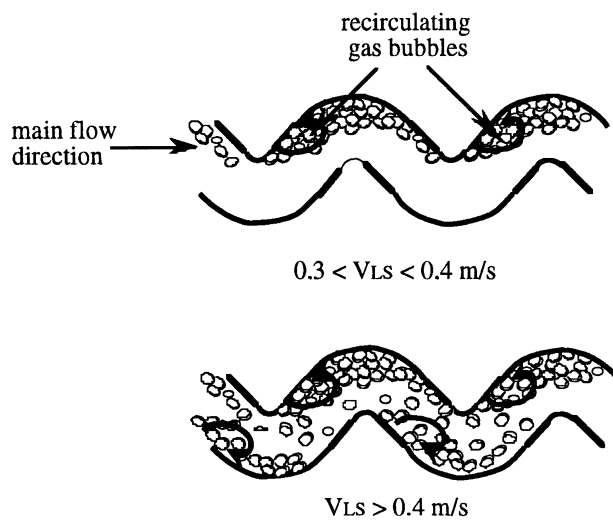

Fig. 6. Schematic of the bubble flow in the 2D channel.

the sub-channels. For superficial liquid velocities in the range 0.2–0.3 m/s, a lateral two-phase flow is observed: the two-phase flow is established in the half part of the channel which is limited by the upper diagonal (in the upper corrugation direction)

3.4. Influence of the flow pattern on the wall shear stress

The wall shear stress gives information not only on the pressure drop but also on the heat transfer efficiency; the thermohydraulic properties of the two-phase flow can be easily obtained from the analysis of the wall shear stress evolutions, the wall shear stress sign and direction. In any case, the two-phase flow value of the mean wall shear stress S was compared to the mean wall shear stress S_0 that occurs in single-phase flow for the same liquid velocity. The heterogeneity of the gas distribution can be clearly demonstrated by the measurement of the wall shear stresses both on the lower and the upper plate.

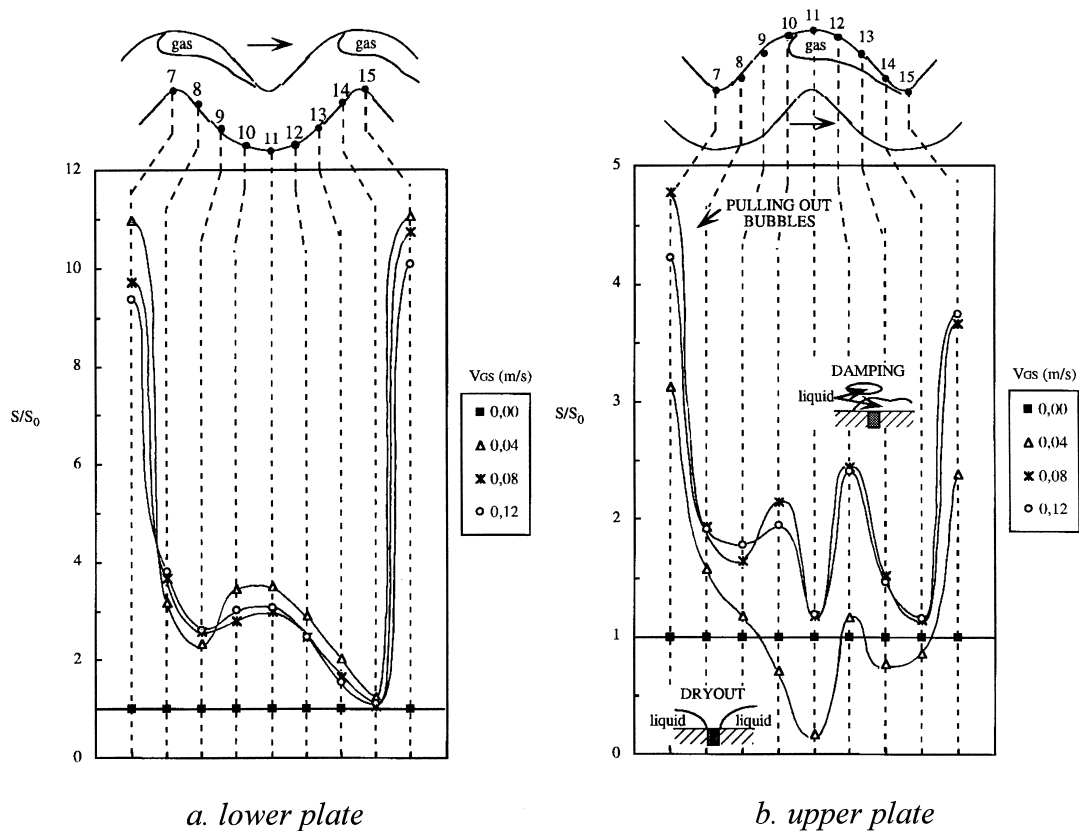

Fig. 7. Typical evolution of the mean wall shear stress in the 2D channel; Stratified flow, $V_{LS} = 0.14$ m/s.

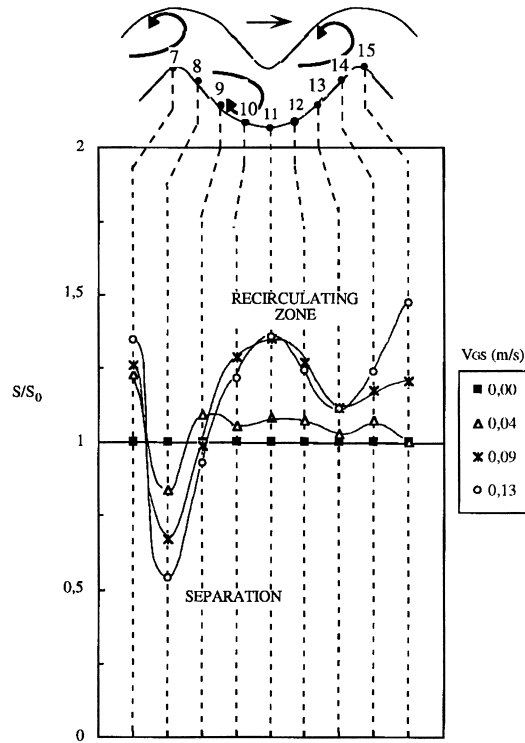

Fig. 8. Typical evolution of the mean wall shear stress in the 2D channel; Bubble flow, $V_{LS} = 0.65$ m/s.

3.5. Case of the 2D channel: mean wall shear stress

Figs. 7 and 8 present some evolutions of the S/S_0 ratio for the two observed regimes. In stratified flow, the mean wall shear stress can reach twelve times its monophasic value on the probes embedded on the crest of the lower plate (probes 7 and 15). These particular evolutions show that the gas phase trapped in the upper corrugations induces a Venturi effect (Fig. 7a):

- S/S_0 strongly increases: the liquid phase is accelerated between the probes 14 and 15 (convergent zone)
- S/S_0 decreases: the liquid phase is decelerated between probes 7 and 9 then the ratio S/S_0 increases again because of the bubbles pulling out. Then, the influence of the gas phase on the liquid becomes negligible (probe 14).

The measurements of the mean wall shear stress on the upper plate give information on the gas flow mechanisms (Fig. 7b):

- the S/S_0 values on probes 7 and 15 are high (close to 3) because bubbles are pulling out
- these values decrease lower than unity (probes 10 and 11) because of wall dryout
- the sudden rise on probe 12 shows that the wall is wetted from time to time

In Bubble flow (Fig. 8), the evolutions of the S/S_0 ratio remain close to unity; that is to say

that the influence of the gas phase is not so strong as in the case of Stratified flow; however, its analysis reveals its particular dynamic structure; namely recirculating zones in the wake of the corrugation that we could observe before (Fig. 6):

- although there is no dryout, the S/S_0 values are lower than one on probe 8; this probe is near a separation point for which the wall shear stress is known to be zero.
- the maximum values of the S/S_0 ratio are observed in probes 9, 10 and 11 because of the recirculating zones due to the gas bubbles

3.6. Case of the 3D channel: mean wall shear stress

Of course, the evolution of the mean wall shear stress in the 3D channel is somewhat different than in the 2D channel. The main differences come from the gas flow (case of Stratified flow) and from bubble motion (case of Bubble flow). In the first case, the gas flows more freely than in the 2D channel (trapped gas phase) both along the upper furrows and in the sub-channels: the typical S/S_0 ratio evolutions (Fig. 9a) exhibit two peaks due to the gas flow in the sub-channels; the liquid flow along the lower furrows seems to have much less

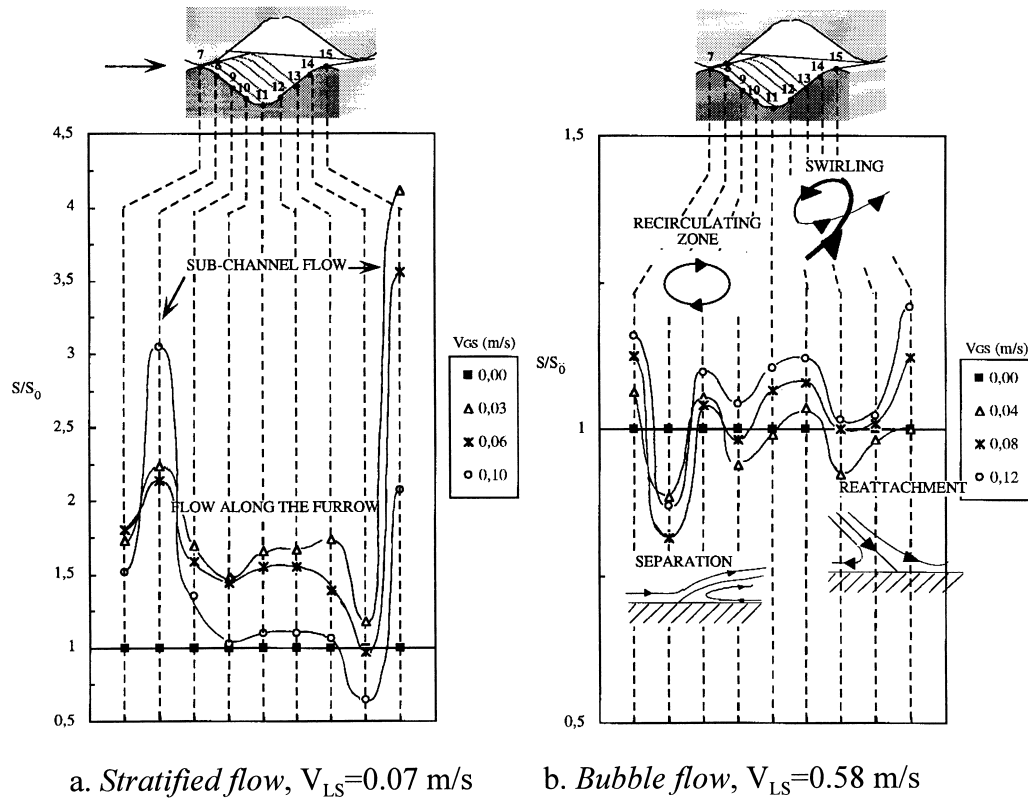

Fig. 9. Typical evolution of the mean wall shear stress in the 3D channel.

influence. In the case of Bubble flow, the typical evolutions of the S/S_0 ratio (Fig. 9b) exhibit still two peaks which are strong characteristics of swirling. The first one seen on probe 9 is due to a vortex which is localized in the wake of the contact point between plates. The second peak (probe 11) reveals the existence of swirling flow which lives in the furrow. The higher values of the S/S_0 ratio are measured on the crest of the corrugations.

4. Conclusion

The two-phase structure of gas–liquid mixtures flowing inside horizontal corrugated channels exhibits peculiar features. Comparison of these with the flow patterns in smooth channels clearly shows that the main differences come from:

- the flow of the gas phase when separation is complete (stratified flow) because of the corrugations acting as obstacles
- the motion of the bubbles when the gas phase is dispersed in the liquid (bubble flow) because of the transversal pressure gradient that produces recirculating bubble zones in the wake of corrugations.

References

- Bereiziat, D. 1993. Structure locale de l'écoulement de fluides newtoniens et non-newtoniens en canaux ondulés. Application à l'échangeur de chaleur à plaques. Thèse de doctorat, INPL, Nancy.
- Gradeck, M., Lebouché, M., 1998. Wall shear measurements inside corrugated channels using the electrochemical technique. *Experiments in Fluids* 24, 17–26.
- Hugonnot, P., Vidil, R., Lebouché, M. 1989. Flow regimes in a corrugated channel: experimental and numerical approaches. Application to plate heat exchange. Ninth Eurotherm Symposium, RFA.
- Lebouché, M. 1968. Contribution à l'étude des mouvements turbulents par la méthode polarographique. Thèse de Docteur ès Sciences, Nancy.
- Reiss, L.P., Hanratty, T.J., 1963. An experimental study of the unsteady nature of the viscous sublayer. *AICHE J* 9, 154–160.
- Souhar, M., Cognet, G., Lebouché, M., 1984. Wall shear stress measurements by electrochemical probe for gas–liquid two-phase flow in vertical duct. *AICHE J* 30, 138–144.